

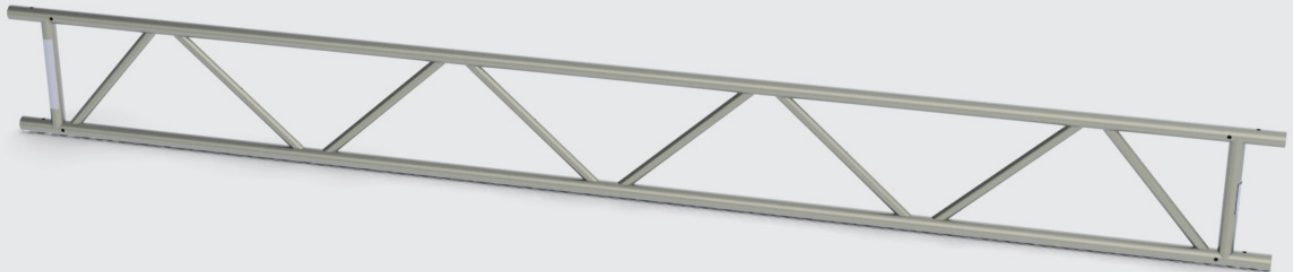

# 2 Chord Unit Beam

Type 4  
0.4m Centres

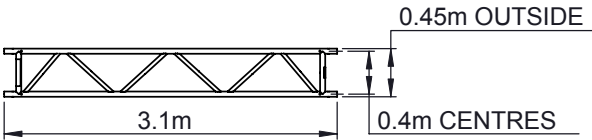
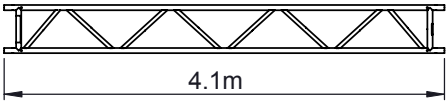
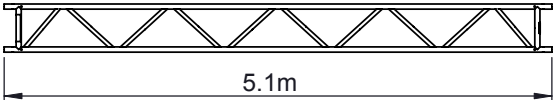
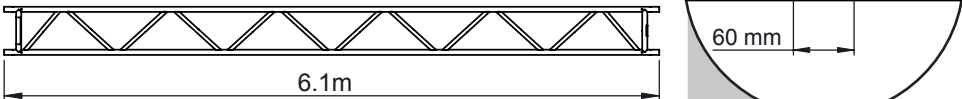
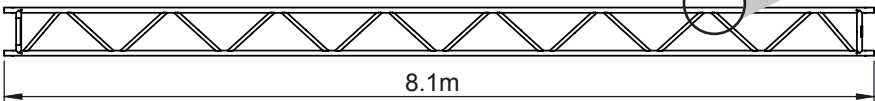

	Length (m)	Product Code
	3.1	200018
	4.1	200019
	5.1	200020
	6.1	200021
	8.1	200022

**Edition 1:2009**

# YOUNGMAN

INNOVATIVE WORK AT HEIGHT SOLUTIONS



**LLOYDS  
BRITISH**

Tested by  
Lloyds British Testing Ltd.

[youngmangroup.com](http://youngmangroup.com)

# 2 Chord Unit Beam

## Type 4 0.4m centres

The Youngman range of unit beams have been designed utilising the company's many decades of aluminium engineering expertise. Manufactured at our state-of-the-art production facility at Maldon, Essex in accordance with ISO 9000 they are connected using steel spigots and bolts or traditional scaffold sleeves

The Youngman aluminium unit beams offer the following features and benefits:

- Designed in accordance with all relevant British and European standards
- Lightweight aluminium construction – less than half the weight of steel
- Range of beam sizes
- All joints fully welded using the latest CMT technology
- All node gaps large enough to connect a standard scaffold fitting
- Easy to handle
- A cost effective solution

At Youngman, safety is our number one priority and whilst we have thoroughly tested all our beams and published all the technical data, it is essential that you consult a qualified structural engineer before incorporating any aluminium beams into load bearing or support structures.

Our aluminium unit beams can be used by scaffolding contractors for many different applications including:

- Provision of a high clearance span
- Support of high weight loadings – carry greater weights than standard scaffold tube
- Temporary roof structures
- Mobile roofs
- Roof edge protection
- Temporary buildings
- Scaffold bridging structures
- Work platforms
- Cantilevers
- Protection fans
- Loading gantries
- Weather protection structures
- Portal frames
- Lighting support beams

### Load Locations

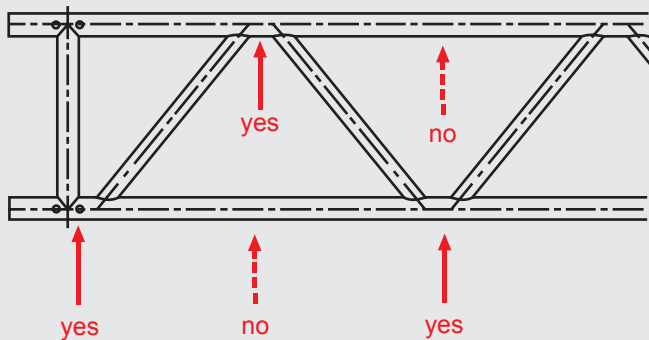

### Support Locations

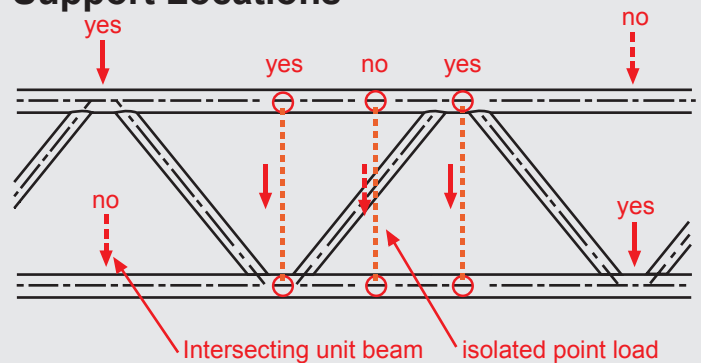

### Splice Locations

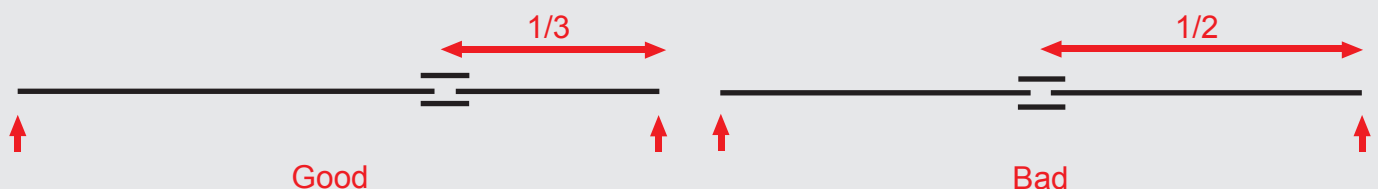

**Youngman Group Ltd**  
The Causeway, Maldon,  
Essex, CM9 4LJ,  
United Kingdom

t +44 (0) 1621 745900  
f +44 (0) 1621 859845  
e [sales@youngmangroup.com](mailto:sales@youngmangroup.com)

**YOUNGMAN**  
INNOVATIVE WORK AT HEIGHT SOLUTIONS

[youngmangroup.com](http://youngmangroup.com)